

D521 Frequency based Speed Monitor Series with optional Analog Output

Instructions and Operation Manual

valid for Serial Nos exceeding
203934

| Contents | page |
|---|-------------|
| Specifications and Key to Model Nos | 2 |
| Short form Instructions for Use | |
| Display and Operational Elements..... | 3-4 |
| Programming | |
| Summary of programming steps..... | 5-6 |
| Procedure | 7 |
| Detailed information about program steps and parameters | |
| Access, minimum period, starter phase time elapse..... | 8 |
| Measurement configuration | 9 |
| Input | 9-10 |
| Display..... | 10 |
| Analog output..... | 11 |
| Setpoint alarms | 11-12 |
| Data Interface | 12 |
| Installation | |
| Safety notes..... | 13 |
| Dimensions..... | 14 |
| Function diagram and terminal Nos | 15 |
| Sensor connection diagrams | 16 |

11.2006: Baudrate Descr. + Initvalue
12.2006: Wiring of SP3 and SP4
06.2008: Wiring Halleffekt-Sensors modified
Rev.02: Pulse Output on terminal 20 obsolete
Rev.03: Pulse Output on terminal 20 reintroduced

Specifications

Application and Functions

Speed monitoring with increased safety. Specifically by incorporated sensor circuit monitoring, and capability to perform permanent plausibility check.
Alarm outputs (2 relay + optional 2 electronic solid state).
Isolated analog output as option.

Model No. Code

D521.02: 2 setpoint alarms with SPDT relay outputs
D521.04: 2 setpoint alarms with SPDT relay outputs + 2 more setpoint alarms with electronic outputs
D521.12: 1 analog output + 2 setpoint alarms with SPDT relay outputs
D521.14: 1 analog output + 2 setpoint alarms with SPDT relay outputs + 2 more setpoint alarms with electronic outputs

Design

snap-on track enclosure fitting DIN 50022 rail 35 mm,
Dimensions:
.....length 70 mm, width (including terminal blocks) 104 mm, height 110 mm
Weight:approx 0.4 kg

Installation Conditions

Ambient temperature in operation 0°C...+60°C
Ambient temperature in storage -40°C...+85°C
Electrical insulation grade..... I
Voltage grade I
Protection grade terminals IP20
..... enclosure IP 40

Power Supply

Supply voltage: 20...265 volts AC/DC
Power Consumption 5 W resp. 5 VA

Signal input

Response (characteristics programmable)
of the standard (V) input path:
response level on/off >6.5volts/<5.6 volts
input impedance 100 kohms
sensor supply approx. 12 volts/max. 60 ma
to NAMUR type sensors: >6.2/<5.8 volts
..... (at incorporated load of 1k with 8 volts supply source)

of the high sensitive (mV) in put path:
response to > 50 mV eff

Measurement

Sequence (programmable) 5 msec – 100 sec
Accuracy..... ± 0.05 % of measurement ± 1 in LSD

Speed Setpoint Outputs

Standard: 2 alarms with SPDT relay contacts
handling capacity: voltage max 250 v AC/DC (minimum 10 mV)
current max 2 amp AC, 1 amp DC (minimum 10 µamp)
power rating max 100 W, 250 VA into ohmic load only
(inductive loads need overload protection)
Option: 2 additional alarms with solid state electronic contacts
handling capacity: voltage max 60 V DC (minimum 10 mV)
.....current max 0, 1 amp DC (minimum 10 µamp)
..... power rating max 2 W

Analog output (optional)

isolated and programmable0/2-10volts/0/4-20ma
resolution12 bit
max. load 750 ohms(with ma), 3 ma (with volts)
linearity error..... < 0.1 %

Display

..... 5 digits LED red, 9 mm, with adjustable decimal point

Data Interface

..... RS 232

Display and Operating Elements

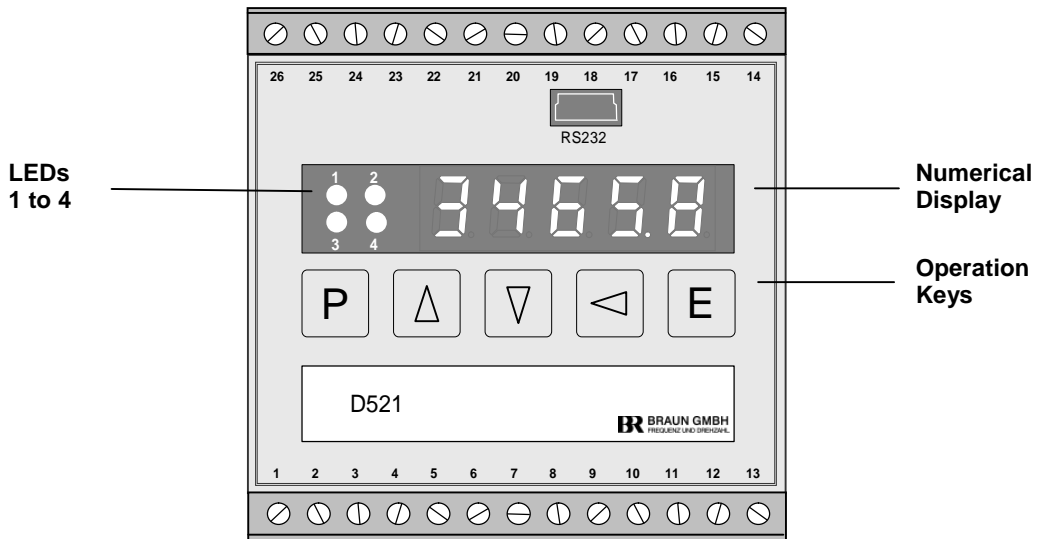

Display Instructions

Numerical Display

In normal operation the display reads the speed in programmed unit and decimals.

In the programming phase the display indicates program step No., resp. the corresponding parameter.

Error signal:

-E1- : unauthorized access with incorrect code No.

LEDs 1 to 4 indicate excess of setpoints SP1 to SP4.

Display readings

Measuring Principle

Measurement is based on the frequency of the pulse train representing the speed. Basic quantity is the time between one or a number of its pulses. An automatic function determines this number, in order to maintain a minimum period of time for every measurement to be extended over. This time minimum is programmable to 5 millisecon or more, thus establishing a corresponding averaging and stabilization of measurements.

The corresponding speed value by required terms (unit and decimals), by which the display, the alarm circuit, and the analog output are reading, computes from these measurements. This process further considers the programmed application data (relation between machine speed and signal frequency).

In essence, the ideal combination of fast reaction, high accuracy, and reliability of results.

Accuracy $\pm 0.005\%$ of measured speed ± 1 in LSD

The total low frequency end of performance is programmable.

Performance at Signal Break

In normal operation, the function closely tracks the input sequence, with the programmed performance. After a sudden interrupt of the input pulses, the unit reduces the readings following an automatic step-down sequence. This starts as fast as the most recent measuring sequence before interrupt, but then decreases slower and slower (reciprocal) until it meets the programmed low end.

Signal Input Path (V)

Accepting any sensor which meets these conditions:

V-input path (terminal 14)

| | |
|---|--|
| <p>Response level on/off >7/<5 volts DC with programmable hysteresis Maximum voltage 100 volts Input impedance 100 kΩ Frequency Range 0 ... 100 kHz Input to symmetrical sensor signal programmable. Sensor Supply appr. 11 v/60 ma. 2-leads NAMUR sensors DIN 19234 (if programmed): Current level on/off >2.0 ma/<1,2 ma with programmable hysteresis supply 8 volts with 1k load resistor (incorporated).</p> | <p>corresponding BRAUN Sensors listed in Wiring Diagrams</p> |
| <p>Signal Input Path (mV) Accepting low level sensors, or such with superposed DC- level, or such missing the above specified V-levels. Sensitivity (min amplitude required) depending on signal frequency (with sinusoidal waveform) 500 mv RMS between 0.1 Hz..... 1 Hz 50 mv RMS between 1 Hz ... 10 kHz 500 mV RMS above 10 kHz Max voltage 50 volts with max ± 35 V DC superposed. Input impedance approx. 50 kΩ.</p> | <p>mV input path (terminal 15)</p> |
| <p>Signal low pass filter programmable to off, or to medium transient frequency (50 kHz), or low (10 kHz)</p> | <p>Input frequency filter</p> |
| <p>Sensor monitoring Monitoring sensor current drain, output voltage, and signal activity (if applicable to sensor type)</p> | <p>Input monitoring for in- creased safety</p> |
| <p>Input Pulse Pre-Divider Reducing the input pulse sequence by a programmable factor before further evaluation. Thus compensating any irregularity in the profile scanned.</p> | <p>Input divider</p> |
| <p>Setpoint Speed Alarms Two (optionally four) individual setpoints control an own signal output (2 as standard with relays, 2 as option with solid state electronics). Each with in- dividually programmable response characteristics, and each with programmable starter.</p> | <p>Alarms</p> |
| <p>Analog Output (optional) Output signal isolated and linear as current 0/4... 20 ma into 750 Ω max load, or voltage 0/2 v ...10 volts under max. 10 ma load. Live zero programmable. High and low end of conversion programmable. Resolution 12 bit (1:4096). Stability ± 0.02 % / °C within 0 ...+ 60 °C</p> | <p>Analog output</p> |
| <p>Signal Pulse Output 1 Repeating the input pulse signals by the same sequence, as square wave pulses of approx. 10 volts and 1 kΩ source impedance. Same reference as input.</p> | <p>Pulse outputs</p> |
| <p>Signal Pulse Output 2 Isolated (passive) output by optocoupler, for max load 30v/10ma. Pulse se- quence as reduced by the input pulse divider. Max output frequency 20 kHz (at a 1:1 duty input signal)</p> | |
| <p>Plausibility Check To perform by means of one (or two) of the setpoint alarms. Set to a low end always surpassed in operation, or define a plausibility range between 2 set- points. Use signal outputs as warning alarms. Disengage by the starter capability whenever the machine is not in normal operation phase.</p> | <p>Plausibility check for in- creased safety</p> |

Summary of programming steps and their initial parameters as set on delivery

| program- Step No. | parameter function | data set on delivery *) (initial data) |
|----------------------|--|---|
| P00.00 | Access code request | 0000 |
| .01 | new code figure | 0000 |
| .02 | lock status (1 = unlocked, 0 = locked) | 1 = unlocked |
| .03 | General Definitions minimum measuring time (005....9999 millisec) | 0100 msec |
| .04 | time elapse of starter phase (XXX sec) | 000 (sec) |
| P01.00 | Input Definitions scaling decimals of input signal frequency | 0 = none |
| .01 | value of nominal input frequency | 00100 |
| .02 | decimals of corresponding speed | 0 = none |
| .03 | corresponding speed (unit as desired) | 00100 |
| .04 | low end of speed range | 00001 |
| .05 | hysteresis of response level (0 = standard, 1 = NAMUR) | 0 |
| .06 | low pass filter (0 = off, 1 = medium, 2 = low) | 0 |
| .07 | reserved for future use | 0 |
| .08 | sensor monitoring (0 = off, 1 = on, 2 = on and latched) | 1 = on |
| .09 | mode of monitoring (0 = none, 1 = current, 2 = voltage, 3 = both) | 1 = current |
| .10 | pre-dividing factor (range 001..255) | 001 |
| P02.00 | Display Definitions LSDs on zero | 0 = none |
| .01 | display updating sequence | 0.3 (sec) |
| P03.00 | Analog output high end speed value | 10000 |
| .01 | low end speed value | 00000 |
| .02 | zero level (0 = dead zero, 1 = live zero) | 1 (live zero) |
| .03 | output mode signal voltage (0), current (1) | 1 (current) |
| .04 | output level at sensor fault (0 = no change, 1 = min, 2 = max) | 0 = no change |
| .05 | output characteristics (0 = linear increase, 1 = linear decrease) | 0 = increase |
| P04.00 | Setpoint 1 setpoint SP1 (by same terms as programmed for display) | 01100 |
| .01 | hysteresis bandwidth (XX.1 % of SP1) | 05.0 (%) |
| .02 | hysteresis location (0 = above, 1 = below, 2 = symm) | 1 = below SP |
| .03 | relay state at n > SP1 (0 = energized, 1 = de-energized) | 0 = energized |
| .04 | starter function effective for SP1 (0 = not, 1 = yes) | 0 = not effective |
| .05 | alarm state during starter phase (0 = <, 1 = >) | 0 = < |
| .06 | alarm state at input failure (0 = no influence, 1 = >, 2 = <) | 0 = no influence |
| P05.00 | Setpoint 2 setpoint SP2 (by same terms as programmed for display) | 01200 |
| .01 | hysteresis bandwidth (XX.1 % of SP1) | 05.0 (%) |
| .02 | hysteresis location (0 = above, 1 = below, 2 = symm) | 1 = below SP |
| .03 | relay state at n > SP2 (0 = energized, 1 = de-energized) | 0 = energized |
| .04 | starter function effective for SP2 (0 = not, 1 = yes) | 0 = not effective |
| .05 | alarm state during starter phase (0 = <, 1 = >) | 0 = < |
| .06 | alarm state at input failure (0 = no influence, 1 = >, 2 = <) | 0 = no influence |

summary is continued on next page

| | | | |
|--------|-----------------------|---|-------------------|
| P06.00 | Setpoint 3 | setpoint SP3 (by same terms as programmed for display) | 01300 |
| .01 | | hysteresis bandwidth (XX.1 % of SP1) | 05.0 (%) |
| .02 | | hysteresis location (0 = above, 1 = below, 2 = symm) | 1 = below SP |
| .03 | | relay state at $n > SP3$ (0 = energized, 1 = de-energized) | 0 = energized |
| .04 | | starter function effective for SP3 (0 = not, 1 = yes) | 0 = not effective |
| .05 | | alarm state during starter phase (0 = <, 1 = >) | 0 = < |
| .06 | | alarm state at input failure (0 = no influence, 1 = >, 2 = <) | 0 = no influence |
| P07.00 | Setpoint 4 | setpoint SP4 (by same terms as programmed for display) | 01400 |
| .01 | | hysteresis bandwidth (XX.1 % of SP1) | 05.0 (%) |
| .02 | | hysteresis location (0 = above, 1 = below, 2 = symm) | 1 = below SP |
| .03 | | relay state at $n > SP4$ (0 = energized, 1 = de-energized) | 0 = energized |
| .04 | | starter function effective for SP4 (0 = not, 1 = yes) | 0 = not effective |
| .05 | | alarm state during starter phase (0 = <, 1 = >) | 0 = < |
| .06 | | alarm state at input failure (0 = no influence, 1 = >, 2 = <) | 0 = no influence |
| P08.00 | Data Interface | baud rate (see table) | 3 = 19200 |
| .01 | | "my name" in communication | 008 |

Short form Parameter-programming instruction

Principle: Select a Parameter by it's "Name" **Pgg.ss**,
 where **gg** = Parameter- Group-No. and
ss = Step-No. within Group,

then check it's value and if necessary, modify it.

Programming:

To enter the programming phase, press both keys **P** and **E** simultaneously; instead of normal display, P00.00 will be shown.

Select group- or step-no. with keys **Δ**, **∇**.

Toggle between group- and step-range with key **◀**.

Show parameter's value with key **E**.

Select (move) active digit with key **◀**.

Adjust figure in active digit with keys **Δ**, **∇**.

Acknowledge with key **E**, Cancel (old value still valid) with key **P**.

Return to normal operation with key **P**

Example: change value of parameter P01.01 from 2386 to 2387 or 2385:

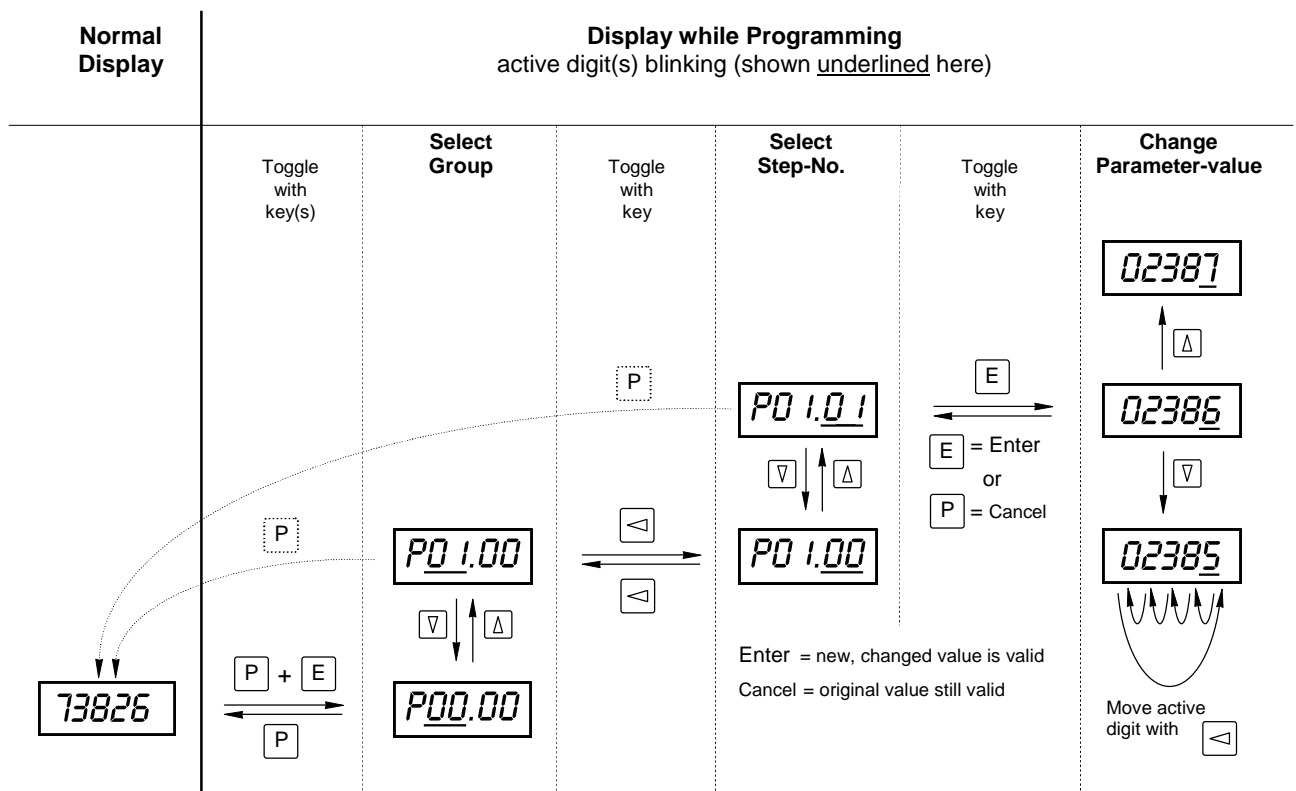

Programmable Parameters:

Parameter Group P00.xx: Data Access, Minimum Measuring Period, Starter Time

Key figure to access

Programming access to all parameters can be locked by a password number. If not properly served, the parameters may be called to display but not varied. If not properly served, the display reads -E1-, and any programming in a later program step will be rejected.

Note:

If the knowledge of the password number went lost it may be recalled to display by a procedure, as described in a separate sheet K0-095 (not included into these instructions). The code figure then appears by 4 digits, headed by a _ sign.

In a subsequent program step, a new code may be established, substituting the one previously valid.

The key function may be disengaged by a next program step. With authorized access, set parameter to 1 in step No .02, to generally unlock the key. This may prove practical during the installation phase to facilitate the adjustments. Once installed, the key function should be reactivated, by programming parameter 0 in this step.

Minimum Measuring Period

The measurement is based on a time interval measurement over a (variable) number of input signal pulses. A programmable minimum measuring period thus will be maintained, automatically including more input pulses into every measurement with increasing input frequency. This establishes an averaging over the programmed period of time, which helps to stabilize the measurements, specifically with fluctuating variables. As a standard, a minimum time of 300 millisecc is recommended. A shorter period should be selected to trace a fast variation (by the analog signal or alarm). A longer period however may be selected to stabilize the measurement against a fluctuating process variable.

The setting of P00.03 defines the minimum measuring period of time, in terms of milliseconds, within a range of 0005....9999 millisecc. A setting less than 00005 is possible, but minimum measuring time will still be 5 msec.

Starter phase time extension

The starter condition is true as long as the contact between terminals 4 and 5 is closed.

The starter condition can be extended by the starter time elapse.

This time starts as soon as the contact between terminals 4 and 5 is opened. The starter time extension is set in program step P00.04 within the range 000...999 (sec). The programmed time is valid for all setpoints.

Step **P00.00**:
Code figure to access

Step **P00.01**:
new code figure

Step **P00.02**:
unlock access key

averaging
over
minimal period of time

Step **P00.03**:
minimum measuring time
0005 msec to 9999 msec.

Step **P00.04**:
Starter phase time extension

Parameter Group P01.xx: Measurement Configuration

Scaling defines the relation between the input signal frequency (in terms of Hz), and the corresponding display (in the unit term and decimal position required by the application). Both values are freely programmable by their decimals and numerical amount. Of course, they must refer to the same operation level. This reference point is recommended close to the high end of the intended operation range. In later operation however, it may be over-run without error.

Example:

A rotating shaft to be measured carries 36 slots. At a shaft speed of 1500 RPM, this produces a signal frequency of 1500 x 36 pulses per minute = 54,000 pulses per minute = 54,000÷60 Hz = 900 Hz. (Presuming the pre-divider is set to 001).

Therefore, 900 (Hz) and 1500 (m/min) are the data-set to be programmed in the corresponding program steps:

Step P01.00 parameter 0 (= no decimal)
P01.01 parameter 00900
P01.02 parameter 0 (= no decimals)
P01.03 parameter 01500.

General Note to Resolution:

Do not use too many decimals! If there are more decimals than justified by the operational fluctuation of the variable, and the transmitter resolution, the minor digits in display will fluctuate accordingly, and also the analog output will not be stable.

Low end of range = shut the performance off

If the variable falls lower than this level, the measurement will be cancelled to zero. With corresponding readings to difference and ratio. This also applies to the analog output and the alarms.

The low end is programmed by the same terms, as defined for the variable by steps P01.02 and P01.03.

Input trigger response hysteresis

Adapting the high level (V) path to the signal source in use.

Parameter 0 = normal hysteresis of 0.8 v to high level sensors,

Parameter 1 = reduced hysteresis of 0.1 v to two-leads NAMUR sensors.

Input signal low-pass filter

Reduces the sensitivity to high signal frequencies to also reduce response to noise signals at the input.

parameter 0 = filter off,

parameter 1 = medium filter with approx 50 kHz transient frequency

Parameter 2 = strong filter effect (approx 10kHz transient frequency)

Step P01.07

Reserved for future applications

Enable/Disable of sensor failure detection

If the sensor is monitored, the failure alarm may be latched until it is reset.

parameter

0 : sensor monitor disabled

1 : active, alarm not latched

2 : active, alarm latched

scaling input

signal frequency (Hz):

Step P01.00 =

number of decimals,

Step P01.01= value.

corresponding value of quantity
(any term):

Step P01.02 =

number of decimals,

Step P01.03 = value

Step P01.04

low end of operating range

Step P01.05

Input response hysteresis

Step P01.06

Input low-pass filter

Step P01.07

Reserved

Step P01.08:

Enables monitoring of sensor

(if applicable to sensor)

Mode of sensor monitoring

The sensor can be monitored for its current drain (alarm if current drops below 7 ma (interrupt) or exceeds 80 ma (short circuit in sensor supply). The signal lead can be monitored (at zero speed) to detect an interrupt there or a wrong connection). This function presumes a strong push-pull sensor characteristics (as with BRAUN A5S.. series of sensors). Requires a jumper between terminals 14 – 16.

Note:

Sensor signal tests in full operation may be performed, using the plausibility check facility (see corresponding paragraph).

Step P01.09:

Mode of sensor monitoring

parameter

0 : no monitoring

1 : current monitoring

2 : signal voltage monitoring

3 : current and signal voltage

Input Predivider

The measuring principle, as explained in the corresponding chapter, calls for an optimum in repeatability in its pulse sequence, or in other words, equal pulse distance at a steady variable. This may be violated by an irregular profile at a speed measurement, or by the typical periodical pulse distance variation during the cycle of an oval gear flowmeter. The input predivider helps to balance this out, when set to the number of pulses included into one period of the fluctuation. It thus reduces the input pulse sequence to 1 pulse per period (= 1 pulse per 1 cycle of the movement).

Set the parameter to this figure (range 001..255).

With a regular input sequence however, use 001 for this parameter.

Note:

The value of the input frequency, as used in program step P01.01, refers to the actual input frequency, *divided* by the pre-divider setting.

Step P01.10

Input predivider

Parameter Group P02.xx:

Display

LSDs on zero

If the display of the speed uses 4 or more digits, for application reasons, the lesser significant digits (LSD) may appear fluctuating. To avoid irritations by not significant digits, a number of them may be permanently kept at zero.

Set the parameter to the number of LSDs to be kept on zero.

Step P02.00:

zeroing LSDs

Display updating sequence

Independent from the response time used for other functions, the display may have its own up-dating sequence - again in the interest of stabilized and well legible readings. Set the parameter to the time in steps of 0.1 sec.

A recommended value is 0.3 sec.

Step P02.01:

display updating

Program Range P03.xx: Analog Output

High end of the conversion span

The high end (corresponding to 20 ma/10 v) is programmed by the same terms (RPM) as used in step P01.03. Independent however, in its level.

Low end of the conversion span

Also, the required low level (corresponding to 0/4ma resp.0/2v).

Note:

This allows the low end to be set as high as 90 % of the high end, resulting in a 10 times spreading (enhancement) of the converted band.

Further enhancement is not recommended.

Analog output zero

The parameter of this step defines:

Parameter 0: without live zero (0..20 ma, 0..10 v)

Parameter 1: with live zero (4..20 ma, 2..10 v)

Output Signal Mode

The output is available as either dc-current (max value = 20 ma) or voltage (max value = 10 volts).

parameter 0 = voltage output

parameter 1 = ma-output

Level of Analog Output at sensor failure condition

Parameter 0: no change of output

Parameter 1: output goes to < 0 ma

Parameter 2: output goes to > 20 ma

Characteristics of Analog Output

Parameter 0: output is increasing with increasing speed

Parameter 1: output is decreasing with increasing speed

With both however, the relation between output signal and quantity measured is linear.

Program Range P04.xx: Defining Alarm SP1

Setpoint

Setpoint SP1 is programmed in the same terms (rpm) as selected for the display of the speed (in step P01.03).

Alarm Hysteresis

The hysteresis is the margin between condition "excess" (>) and "no excess" (<), defined by its bandwidth.. The hysteresis bandwidth is set as a percentage of the setpoint.

Hysteresis position

The hysteresis band may be placed above setpoint, below setpoint, or symmetrically around the setpoint.

"Above" means, the alarm goes to excess state (>) ,when the speed exceeds "setpoint plus tolerance", and it cancels to no-excess (<), when the speed drops below setpoint. Set parameter 0 for this performance.

"Below" means, the alarm goes to excess (>), when the speed exceeds the setpoint, and it cancels to no-excess (<), when the speed drops below "setpoint minus tolerance". Set parameter to 1 for this performance.

In "symmetrical" mode, the alarm goes to excess (>), when the speed exceeds the setpoint by half the tolerance band, and it cancels to no-excess (<), at half the tolerance below setpoint.

Set parameter to 2 for this performance.

Step P03.00:

high end of analog output

Step P03.01:

low end of analog output

Step P03.02:

zero of analog output

Step P03.03

output mode

Step P03.04

Level of analog output at sensor failure condition

Step P03.05

Characteristics of analog output increasing/decreasing

Step P04.00:

Setpoint SP1

Step P04.01:

band width of hysteresis of SP1 as XX.X %

hysteresis position

Step P04.02:

0 :

above SP

1 :

below SP

2:

symmetrical around SP

Relay state assigned to "excess" condition

Without power supply, the alarm outputs are non-conducting, and the relays are de-energized. To consider safety aspects of the application, this No-Power condition can be assigned to either alarm > or < condition by parameter selection:

0 = energized at excess
1 = de-energized at excess

Setpoint included/not included in starter function

This step defines, individually for each alarm, whether or not it is included into the starter function. Thereby it is possible, for instance, to disable a low speed alarm during the starter phase, whereas a high speed alarm remains active all the time.

In the corresponding program step, set

Parameter = 0, to exclude the alarm from the starter function,
parameter = 1, to include the alarm into the starter function

Relay state at starter condition (if included)

Parameter = 0 to throw the alarm to < setpoint,
Parameter = 1 to throw the alarm to > setpoint.

Response of alarm output of SP1 to state "sensor failure"

Selection of :

- ignore sensor failure, normal comparison with speed
- set to no "excess" (n < SP1)
- set to "excess" (n > SP1)

Step P04.03:

relay-state if n > SP1:
setting:

0 : Energized
1 : Deenergized = No-Power
condition

Step P04.04:

Setpoint included/not included in
starter function

0 = not included
1 = included

Step P04.05:

Relay state at starter condition

0 = n < SP1
1 = n > SP1

Step P04.06:

Response to sensor failure

setting:

0: normal speed comparison
1: 'n < SP1' alarm
2: 'n > SP1' alarm

Program Groups P05.xx to P07.xx Performance of Alarms SP2, SP3, SP4

P05.00 through P07.06

These alarms are individually programmed, following the same rules, as given above for Alarm SP1 in Program Group P04.xx

Parameter Group P08.xx Defining Data Interface Parameters (option)

For the operation of the serial data interface (RS 232) these parameters are adjustable:

- by program step P09.00 Baudrate,
- by program step P09.01 "my device" No (address)..

Step P08.00:

Baudrate

setting 1 : 01200 Baud
2 : 09600 Baud
3 : 19200 Baud
4 : 38400 Baud

Step P08.01:

"my device" No (address).

Default Values

The unit is supplied set to the default values as listed in the Summary of programming steps. In process of installation, the adaptation of its parameters inevitably must be adapted to the true values of its application. So, compare the default values listed to the application, and re-program if different.

Installation

The unit is designed for snap-on track mounting. Dimensions are given on the following page.

As a specific version, it can be supplied in a field mounting enclosure (appendix –G to model No.) grade IP65.

Safety Notes

This unit has been designed and inspected according to standards DIN 57 411 / VDE 0411Sect 1, and IEC 348. Observe these instructions and wiring diagrams carefully, to ensure this protection. The installation must only be done by adequately qualified personnel.

General Instructions

Specifically, connect the ground terminal of the instrument to a safe ground potential.

Do not open the instrument. Connections and all programming are done from outside. When removing it from its enclosure however, from whatever reason, make sure that power is switched off.

The instrument may be installed in any position, but not in the immediate neighborhood of interfering sources.

Signal leads must be carefully shielded, and should not be run in bundles with power or relay control leads.

The ground terminal (PE) is internally separated from common zero, but tied by a 100 k resistor to it.

EMI

The unit complies with all relevant regulations, as determined by the Policy of the European Committee for Electrotechnical Standardization (CENELEC), for the Electromagnetic Compatibility (89/336/EWG). Testing and inspection has been performed according to Standards EN 61000-4-2 and EN 61000-4-4. Thereby, the product meets all requirements to be marked by the CE sign.

Strict observance of these instructions during installation and use is an indispensable precondition hereto. Specifically to be observed:

Terminals must be kept off all undue access; power supply and all input and output leads must be protected against voltage interference, higher than specified operation data, and they must be protected against electrostatic discharge.

General information and instructions to installation and wiring.

See last pages for specific wiring diagrams and dimension sheet.

Dimensions (mm) of snap-on-track (standard) version

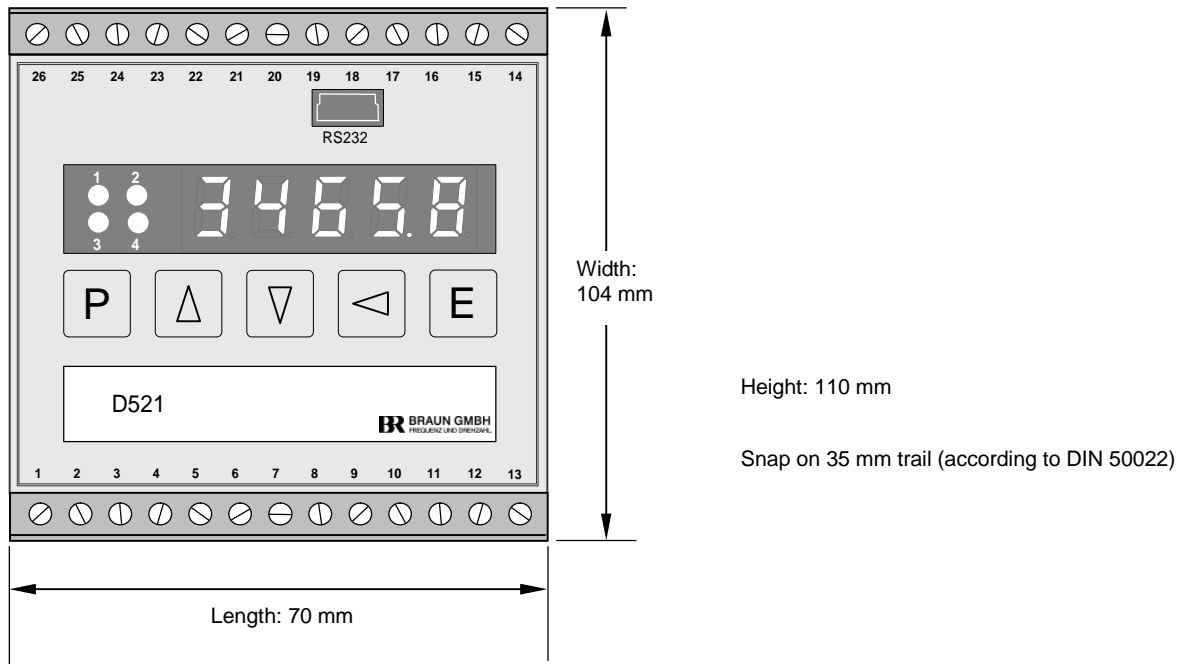

Dimensions of Field Mount Enclosure (-G)

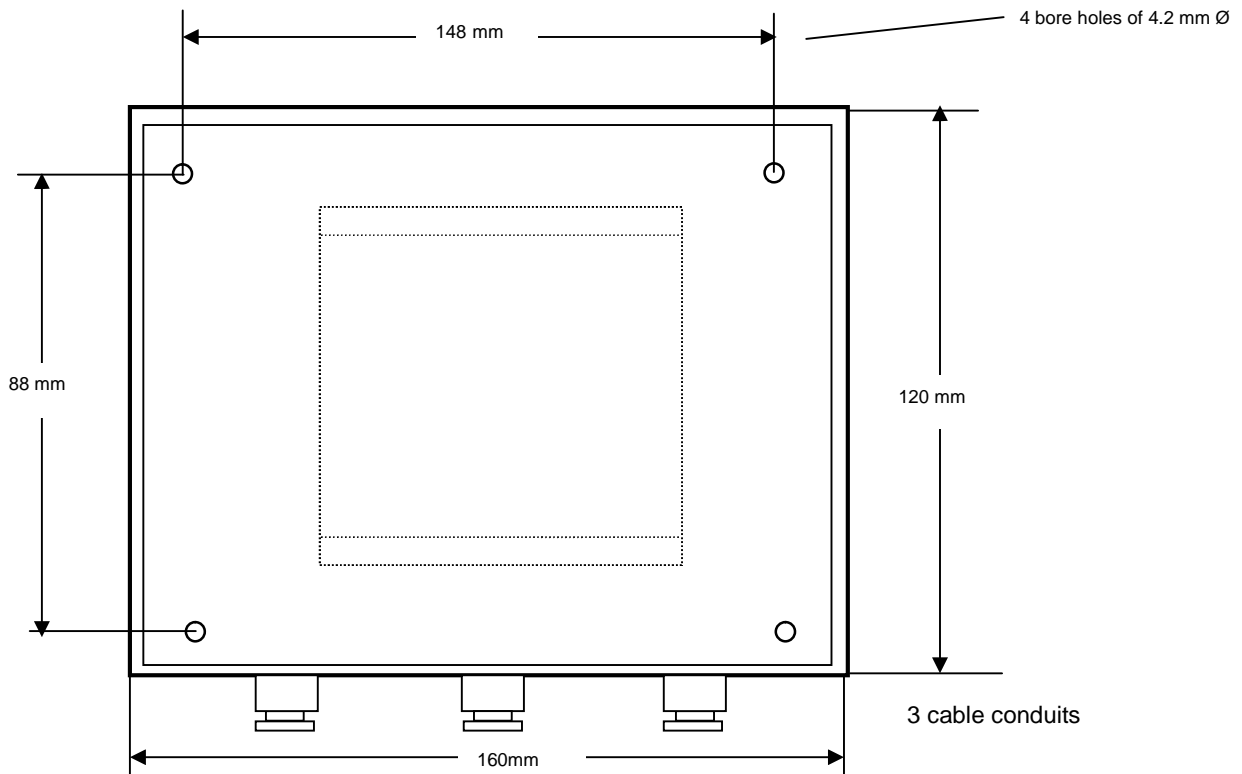

Function diagram and connections

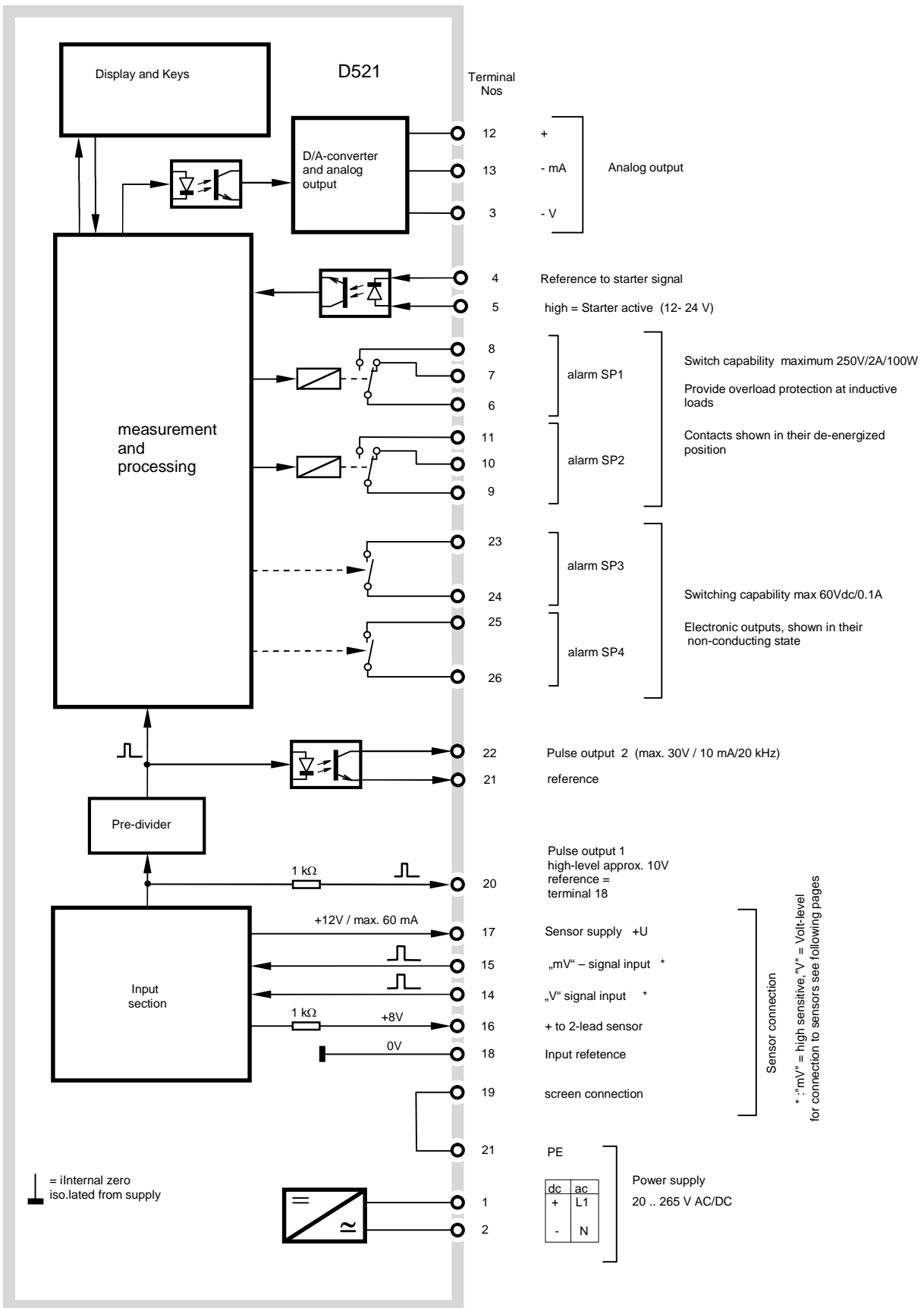

*: „mV” = high sensitive; „V” = Volt-level for connection to sensors see following pages

connections of measuring signals to input

terminals

